

HORIZONTAL SUCTION

Line Accumulators



The refrigeration compressor is designed to compress vapor only. A suction line accumulator prevents compressor damage from a sudden surge of liquid refrigerant and oil which could enter the compressor from the suction line. The suction line accumulator is a temporary reservoir for this mixture, designed to meter both the liquid refrigerant and oil back to the compressor at an acceptable rate. This prevents damage to the reed valves, pistons, rods, and crank shafts. Accumulators range in size from 4" to 123/4" in diameter. All vessels over 6" inside diameter are designed and manufactured in accordance with Section VIII of the ASME Code and are marked with the U or UM Code symbol. Accumulators 6" outside diameter and under are copper brazed or welded, UL listed, and equipped with copper or copper plated fittings. All our accumulators feature a rust resistant finish which meets a 500 hour salt spray test. This is important to suction line accumulators, where moisture and condensation can result in excessive corrosion. Accumulators have a metering ejector device that picks up liquid, vaporizes it, and returns it to the compressor. This prevents liquid slugging and controls oil return. Vertical accumulators protect the return orifice with a screen assembly, and also feature a fusible relief device in the S-7000 Series.

Selection of a suction line accumulator should be made on the basis of the following three capabilities. The accumulator should have an adequate liquid holding capacity, which can vary with the system. Normally this should not be less than 50% of the system charge. If possible this value should be checked based on actual tests. A second consideration should be the ability of the accumulator to perform without adding excessive pressure drop to the system. The recommended maximum tonnages shown in the following tables are based on a pressure drop equivalent to 1/2°F. These ratings are those of the accumulator, based on oil return through the accumulator, and will be modified by the length of the suction line and compressor displacement. Minimum tonnage is the lowest flow that will insure proper oil return. Finally an accumulator should have the capability of returning liquid at the proper rate and under a range of load conditions. Accumulators should have a Heat Element added on low temperature applications (0°F and below) such as the S-9111 or S-9112 (see page 99) to help boil off liquid refrigerant and raise the oil temperature to help facilitate oil flow. Accumulators may be insulated to prevent condensation or frost on the outside of the shell.

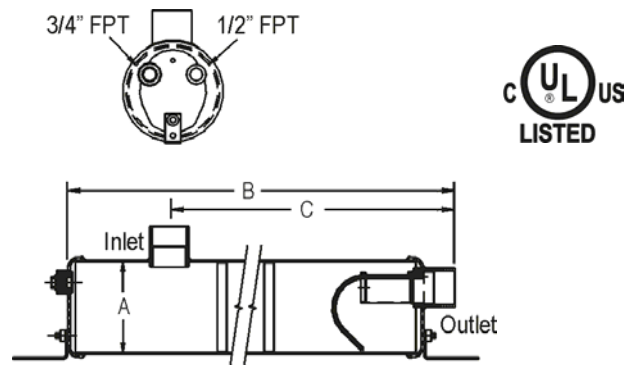

Liquid accumulators of this design should not be used when the temperature of the liquid refrigerant is less than +15°F in the accumulator. These accumulators have a 1/2" FPT connection for liquid injection and a 3/4" FPT connection for hot gas bypass. These connections can also be used for a relief device as required by UL 207.

Catalog Number	Size Conn. ODS	Dimensions in Inches			Refrigerant Holding Cap. (Lbs. 0°F sat.)			Refrigerant Recommended Tons Refrigeration at Suction Evaporating Temperature (°F)								
		A	B	C	R134a	R22	R404a/R507	R-134a			R-22			R-404a / R-507		
								+40°	+20°	0°	+40°	+20°	0°	+40°	+20°	0°
S-7615	1 5/8	6	28	21.5	23.3	21.3	19.3	15	10	6.25	29	20	20	12.5	19	11.5
S-7621	2 1/8	6	36.75	31.6	31.6	29	26.2	28.6	19.5	12.5	50	30	30	25	33.2	22.9
S-7625	2 5/8	6	50	43.5	46.7	42.6	38.6	50	35	23	95	95	65	45	61.7	41.2



VERTICAL SUCTION

Line Accumulators



Max Working Pressure 450 PSI

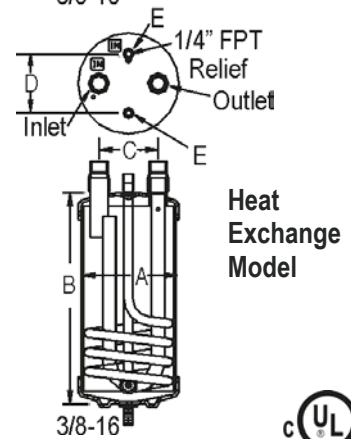
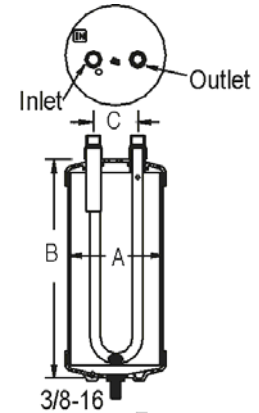

Catalog Number			Dimensions in Inches						ODS *E
STD.	Heat Ex.	Heat Pump	ODS Conn.	Dia. A	B	C	D		
S-7043	—	S-7043HP	5/8	4	6.38	1.88	N/A	N/A	
S-7044	—	S-7044HP	1/2	4	10.38	1.88	N/A	N/A	
S-7045	S-7045HE	S-7045HP	5/8	4	10.38	2.50	2.50	3/8	
S-7046	S-7046HE	S-7046HP	3/4	4	10.38	2.50	2.50	3/8	
S-7057	S-7057HE	S-7057HP	7/8	5	13	2.25	2.75	1/2	
S-7061	S-7061HE	S-7061HP	1-1/8	6	15	3	2.88	5/8	
S-7063S	—	—	1-3/8	6	20.25	3	N/A	N/A	
S-7063	S-7063HE	S-7063HP	1-3/8	6	24.75	3	2.88	5/8	
S-7065	S-7065HE	S-7065HP	1-5/8	6	24.75	3	2.88	3/4	

Catalog Number	Refrigerant Holding Cap. (Lbs. 0°F sat.)			Refrigerant Recommended Tons Refrigeration at Suction Evaporating Temperature (°F)														
	R134a	R22	R404a / R507	R-134a					R-22					R-404a / R-507				
				+40°	+20°	0°	-20°	-40°	+40°	+20°	0°	-20°	-40°	+40°	+20°	0°	-20°	-40°
S-7043	2.3	2.1	1.9	Max. 1.4	0.8	0.5	0.3	0.2	1.9	1.3	0.9	0.6	0.4	2.1	1.4	0.9	0.6	0.3
				Min. 0.3	0.2	0.1	0.1	0.4	0.4	0.3	0.2	0.1	0.1	0.5	0.3	0.2	0.1	0.1
S-7044	4.4	4.1	3.7	Max. 0.7	0.4	0.3	0.2	0.1	1.0	0.7	0.5	0.3	0.2	1.1	0.7	0.5	0.3	0.2
				Min. 0.2	0.1	0.1	0.1	0.2	0.2	0.1	0.1	0.1	0.1	0.2	0.2	0.1	0.1	0.3
S-7045	4.4	4.1	3.7	Max. 1.4	0.8	0.5	0.3	0.2	1.9	1.3	0.9	0.6	0.4	2.1	1.4	0.9	0.6	0.3
				Min. 0.3	0.2	0.1	0.1	0.4	0.4	0.3	0.2	0.1	0.1	0.5	0.3	0.2	0.1	0.1
S-7046	4.4	4.1	3.7	Max. 1.9	1.1	0.7	0.4	0.2	2.7	1.8	1.2	0.8	0.5	2.9	1.9	1.2	0.8	0.5
				Min. 0.4	0.2	0.2	0.1	0.5	0.6	0.4	0.3	0.2	0.1	0.6	0.4	0.3	0.2	0.1
S-7057	9.2	8.5	7.7	Max. 3.2	1.9	1.2	0.7	0.4	4.5	3.1	2.1	1.3	0.8	4.8	3.2	2.1	1.3	0.8
				Min. 0.6	0.4	0.2	0.1	0.1	0.9	0.6	0.4	0.3	0.2	0.9	0.6	0.4	0.3	0.2
S-7061	12.7	11.8	10.7	Max. 6.6	3.9	2.4	1.4	0.8	9.3	6.5	4.3	2.7	1.7	10.0	6.6	4.3	2.6	1.6
				Min. 1.0	0.6	0.4	0.2	0.1	1.5	1.0	0.7	0.4	0.3	1.6	1.0	0.7	0.4	0.2
S-7063S	17.1	15.4	14.0	Max. 11.0	6.4	4.0	2.4	1.3	15.4	10.7	7.0	4.5	2.8	16.5	10.9	7.0	4.4	2.6
				Min. 2.1	1.2	0.8	0.5	0.3	3.0	2.0	1.4	0.9	0.5	3.2	2.1	1.4	0.9	5.5
S-7063	21.8	20.1	18.2	Max. 11.0	6.4	4.0	2.4	1.3	15.4	10.7	7.0	4.5	2.8	16.5	10.9	7.0	4.4	2.6
				Min. 2.1	1.2	0.8	0.5	0.3	3.0	2.0	1.4	0.9	0.5	3.2	2.1	1.4	0.9	5.5
S-7065	21.8	20.1	18.2	Max. 19.3	11.3	7.0	4.2	2.4	27.2	18.8	12.4	7.9	4.8	29.1	19.1	12.4	7.7	4.6
				Min. 3.7	2.1	1.3	0.8	0.5	5.1	3.6	2.4	1.5	0.9	5.5	3.6	2.4	1.5	0.9



ASME VERTICAL SUCTION

Line Accumulators



Constructed to
ASME
U or UM
PED

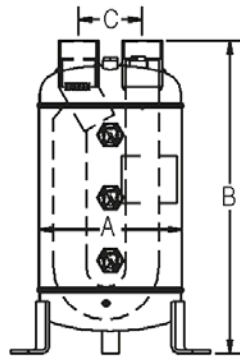
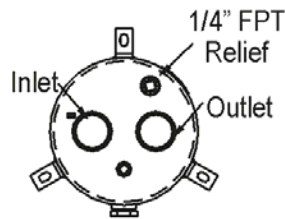

Max. WP 400 PSI

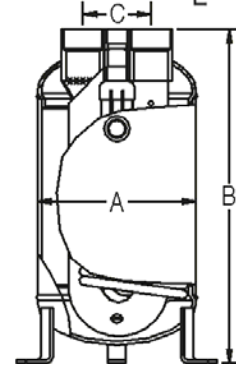
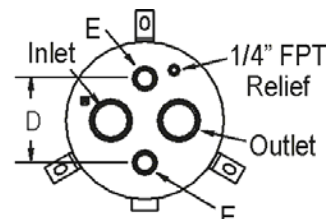

Heat Exchange model

* Suitable for Ammonia

Catalog Number			ODS Conn	Dimensions in Inches				
1" FPT Model	STD	Heat Exchanger		Dia. A	B	C	D	ODS E
S-7722*	S-7721*	S-7721HE	2 1/8	8 5/8	23.13	3.50	5.50	7/8
S-7726*	S-7725*	S-7725HE	2 5/8	10 3/4	22.75	4.63	5.50	1 3/8
S-7732*	S-7731*	S-7731HE	3 1/8	12 3/4	25.00	5.50	5.88	1 3/8
NA	S-7741*	S-7741HE	4 1/8	16	35.50	Contact Factory	Contact Factory	2 5/8
NA	S-7742*	—	4 1/8	20	44.50	Contact Factory	Contact Factory	N/A

HE: Heat Exchange models available by ordering with an HE suffix

(ie. S-7721HE). Heat Exchange models feature a boil out coil to boil off liquid refrigerant in the bottom of the accumulator. The ODS connection size of the boil out coil is shown in column E.

Optional: 1" FPT connection is available on S-7700 series for installation of a S-9400-1 type Liquid Level Switch. Consult factory.

CE: To order CE version, add "-CE" suffix.

Cat. No.	Refrigerant Holding Cap. (Lbs. 0°F sat.)			Refrigerant Recommended Tons Refrigeration at Suction Evaporating Temperature (°F)																													
	R134a	R22	R404a /R507	R-134a					R-22					R-404a / R-507																			
				+40°	+20°	0°	-20°	-40°	+40°	+20°	0°	-20°	-40°	+40°	+20°	0°	-20°	-40°															
S-7721	32.5	27	27	Max. 43.0	25.1	15.6	9.3	5.2	60.4	41.8	27.6	17.7	10.8	64.7	42.5	27.6	17.1	10.1	Min. 7.7	4.5	2.8	1.7	0.9	10.9	7.5	5.0	3.2	1.9	11.7	7.7	5.0	3.1	1.8
S-7725	48.5	40	40	Max. 64.0	37.4	23.2	13.8	7.8	90.0	62.2	41.1	26.3	16.1	96.5	63.4	41.1	25.5	15.1	Min. 12.8	7.5	4.6	2.8	1.6	17.9	12.4	8.2	5.3	3.2	19.2	12.6	8.2	5.1	3.0
S-7731	80	66	66	Max. 95.0	55.5	34.5	20.5	11.6	133.5	92.4	60.9	39.1	23.8	143.1	94.0	61.0	37.8	22.4	Min. 19.1	11.1	6.9	4.1	2.3	26.8	18.6	12.2	7.9	4.8	28.8	18.9	12.3	7.6	4.5
S-7741	136	135	122	Max. 149.4	87.2	54.2	32.2	18.2	209.9	145.2	95.8	61.4	37.5	225.1	147.9	95.9	59.4	35.3	Min. 48.2	28.1	17.5	10.4	5.9	67.7	46.9	30.9	19.8	12.1	72.6	47.7	31.0	19.2	11.4
S-7742	297	277	251	Max. 149.4	87.2	54.2	32.2	18.2	209.9	145.2	95.8	61.4	37.5	225.1	147.9	95.9	59.4	35.3	Min. 48.2	28.1	17.5	10.4	5.9	67.7	46.9	30.9	19.8	12.1	72.6	47.7	31.0	19.2	11.4



SUCTION ACCUMULATORS



Suitable for Ammonia



Max Working Pressure 450 PSI

Oil Return is assured from the standard accumulator through the internal U-tube at full gas flow conditions. The use of compressor suction un-loaders will reduce the gas CFM flow rate and oil return will be affected if maintained over a long period. Hot gas bypass for capacity reduction will maintain constant CFM. The U-tube may not be required under conditions where oil rich refrigerant can be drained from the bottom of the accumulator through a needle valve, sight glass and solenoid valve (cycle with the compressor). The needle valve should be set to flash off the refrigerant and the oil bled by gravity into the suction line. A Boil-Out is recommended under low temperature conditions and is essential for all hot gas defrost systems. The liquid line should be routed through the boil-out coil to provide a steady heat source to evaporate off liquid trapped in the accumulator. The liquid should be evaporated before commencement of the next defrost cycle.

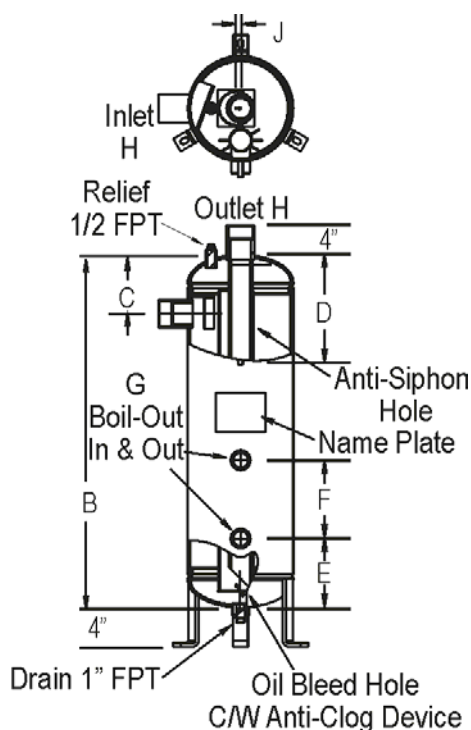

Max. CFM	Catalog No.	Refrigerant Trapping Capacity** (Lbs.)			Approx. Shipping Wt. Lbs.	Dimensions in Inches								
		R12	R22	R502		A	B	C	D	E	F	G*	H*	J
40	AF06018	15	15	16	32	6 5/8	18	5 1/4	6 1/2	4 3/4	8	1 1/8	2 1/8	1 1/4
40	AF06024	24	24	25	41	6 5/8	24	5 1/4	6 1/2	4 3/4	8	1 1/8	2 1/8	1 1/4
40	AF06030	33	33	34	50	6 5/8	30	5 1/4	6 1/2	4 3/4	8	1 1/8	2 1/8	1 1/4
70	AF08024	37	37	38	57	8 5/8	24	5	6 1/2	4	8	1 1/8	2 5/8	1 9/16
70	AF08030	51	51	53	69	8 5/8	30	5	6 1/2	4	8	1 1/8	2 5/8	1 9/16
70	AF08036	66	66	69	81	8 5/8	36	5	6 1/2	4	8	1 1/8	2 5/8	1 9/16
70	AF08042	81	81	85	91	8 5/8	42	5	6 1/2	4	8	1 1/8	2 5/8	1 9/16

*G and H Connections shown are Maximum available.

**Trapping Capacity is the weight of refrigerant the suction accumulator can safely hold without the risk of carry-over into the compressor suction line.



SUCTION ACCUMULATORS

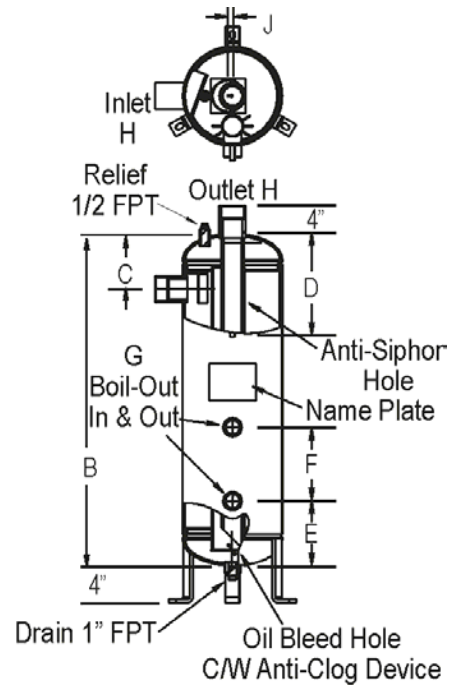

*G and H Connections shown are Maximum available.
 **Trapping Capacity is the weight of refrigerant the suction accumulator can safely hold without the risk of carry-over into the compressor suction line.
 + Custom Built (Non-Stock Item)

Max CFM	Catalog Number	Refrigerant Trapping Capacity** (Lbs.)			Approx Shipping Wt. Lbs.	Dimensions in Inches								
		R12	R22	R502		A	B	C	D	E	F	G*	H*	J
110	AF10030	77	77	80	100	10 3/4	30	6	7 1/2	7	8	1 5/8	2 5/8	1 9/16
110	AF10036	101	101	105	117	10 3/4	36	6	7 1/2	7	8	1 5/8	2 5/8	1 9/16
110	AF10042	124	124	129	135	10 3/4	42	6	7 1/2	7	8	1 5/8	2 5/8	1 9/16
110	AF10048	145	145	150	152	10 3/4	48	6	7 1/2	7	8	1 5/8	2 5/8	1 9/16
155	AF12030	100	99	104	132	12 3/4	30	8	9 1/4	7	8	1 5/8	3 1/8	5/16
155	AF12036	133	132	138	155	12 3/4	36	8	9 1/4	7	8	1 5/8	3 1/8	5/16
155	AF12042	166	165	172	178	12 3/4	42	8	9 1/4	7	8	1 5/8	3 1/8	5/16
155	AF12048	198	197	206	200	12 3/4	48	8	9 1/4	7	8	1 5/8	3 1/8	5/16
195	AF14042 +	177	176	184	273	14	42	9	11	8	10	2 1/8	4 1/8	3/4
195	AF14048 +	216	215	225	311	14	48	9	11	8	10	2 1/8	4 1/8	3/4
195	AF14054 +	256	254	266	346	14	54	9	11	8	10	2 1/8	4 1/8	3/4
195	AF14060 +	299	296	310	384	14	60	9	11	8	10	2 1/8	4 1/8	3/4
255	AF16042 +	195	194	207	325	16	42	10	13	9	10	2 1/8	5	3/8
255	AF16048 +	256	253	265	365	16	48	10	13	9	10	2 1/8	5	3/8
255	AF16060 +	352	350	371	448	16	60	10	13	9	10	2 1/8	5	3/8
255	AF16072 +	460	457	485	535	16	72	10	13	9	10	2 1/8	5	3/8
405	AF20048 +	335	332	350	472	20	48	11	13	10	10	2 5/8	5	2 1/4
405	AF20060 +	528	525	549	572	20	60	11	13	10	10	2 5/8	5	2 1/4
405	AF20072 +	680	676	707	672	20	72	11	13	10	10	2 5/8	5	2 1/4
405	AF20084 +	775	770	806	772	20	84	11	13	10	10	2 5/8	5	2 1/4
590	AF24048 +	530	526	550	600	24	48	13	16 1/4	10	10	2 5/8	6	2 1/4
590	AF24060 +	720	715	750	712	24	60	13	16 1/4	10	10	2 5/8	6	2 1/4
590	AF24072 +	919	913	955	836	24	72	13	16 1/4	10	10	2 5/8	6	2 1/4
590	AF24084 +	1159	1152	1205	960	24	84	13	16 1/4	10	10	2 5/8	6	2 1/4

