

# EXPANSION VALVES

## Screw-End, Hand-wheel Type



Suitable for Ammonia



### Features:

- **Valve Bodies:** Ductile Iron
- **Valve Bonnets:** Flange design, Ductile iron
- **Stems:** Plated Steel
- **Backseating:** Can be repacked under pressure
- **Temperature Range:** -20°F(-29°C) to +325°F(+163°C)
- **Maximum cold working pressure:** 400 PSI (28.1 Kg/cm<sup>2</sup>)
- **Individually packaged and labeled**
- **Suitable for ammonia,** refrigerants and other industrial fluids non-corrosive to steel and ductile iron

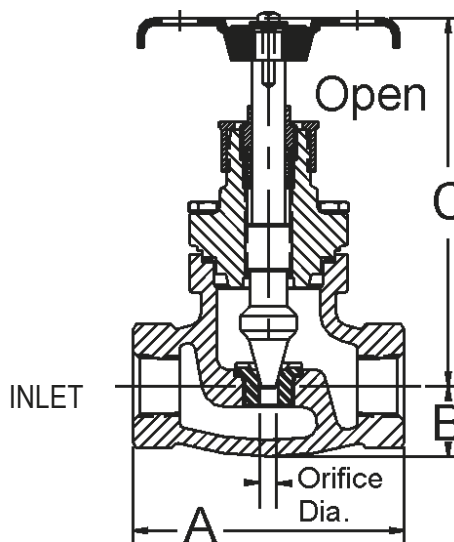

F.P.T. Connection	Catalog Numbers	Dimensions in Inches			Orifice Diameter	Weight lbs.
		A	B	C		
1/2"	320F-E	3.63	1.13	5.00	.25	2.5
3/4"	330F-E	3.63	1.13	5.00	.38	2.5
1"	340F-E	4.13	1.13	5.25	.50	3.5