

STRAINERS

Straight Through



Specifications:

- Steel
- Stainless steel screen
- Maximum working pressure: 500 PSI (35 Kg/cm²)
- Temperature rating: -20°F (-29°C) to +300°F (+149°C)
- Suitable for refrigerants and other industrial fluids non-corrosive to steel and copper

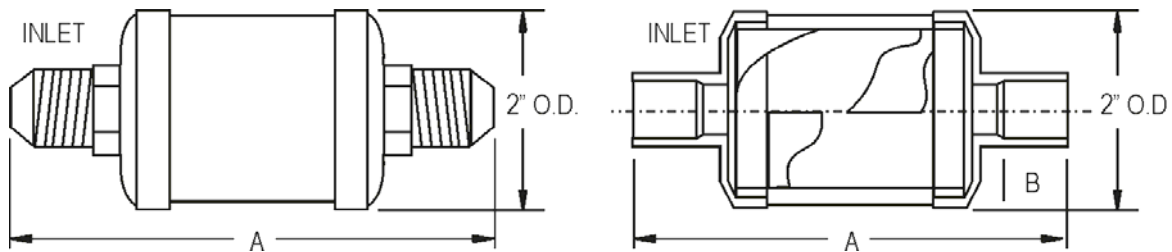

Catalog Numbers	Size Connection	Dimensions in Inches		Screen Data		Wt. Lbs.
		A	B	Area Sq. In.	Mesh	
891S-1/4	1/4" FL	4.50	—	11	100	.48
891S-3/8	3/8" FL	5.00	—	11	100	.57
891S-5/8S	5/8" ODS	4.56	.50	11	100	.72

STRAINERS

Y - Type



Specifications:

- Forged brass body and brass clean-out plug
- Maximum working pressure: 500 PSI (35 Kg/cm²)
- Screen monel
- Temperature rating: -20°F (-29°C) to +200° F (+93°C)
- Suitable for refrigerants and other industrial fluids non-corrosive to brass

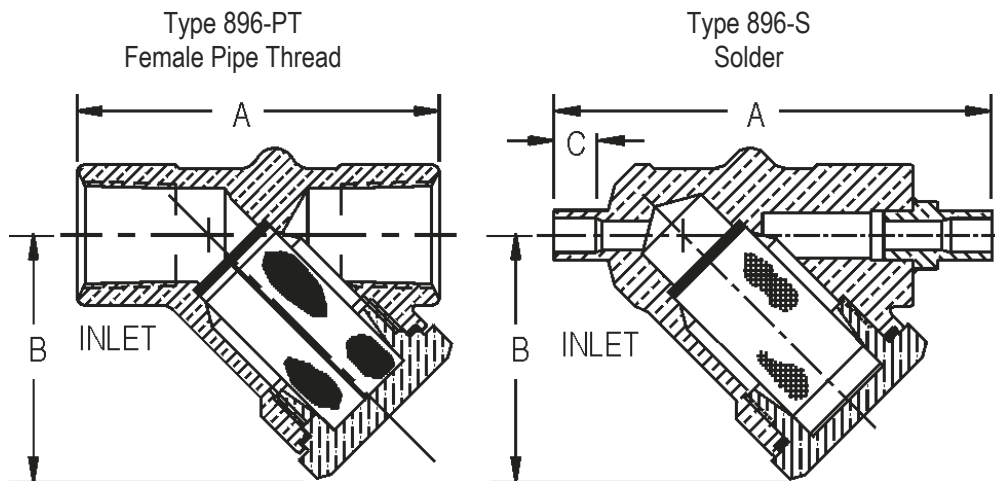

Catalog Numbers	Size Connection	Dimensions in Inches			Screen Data		Wt. Lbs.
		A	B	C	Area Sq. In.	Mesh	
896-1/4PT	1/4 NPTF	2.19	1.63	—	2	100	.55
896-3/8PT	3/8 NPTF	2.19	1.63	—	2	100	.51
896A-3/8S	3/8 ODS	3.31	1.88	.44	3	100	.84
896A-1/2S	1/2 ODS	3.38	1.88	.56	3	100	.82
896A-5/8S	5/8 ODS	3.50	1.88	.63	3	100	.80
896B-5/8S	5/8 ODS	4.44	2.56	.63	7	100	2.50