

PACKLESS VALVES

Golden Bantam® Type



Features:

- **Forged brass cored body** provides durability, maximum rigidity, strength. Integral mounting bracket on valves simplifies installation
- **Forged brass bonnet** machined to provide support for diaphragms when valve is wide open
- **Hermetic seal** between bonnet, diaphragms and body
- **Large diameter diaphragms** of dissimilar metals permit greater lift, aids flow and longer life. Phosphor bronze for longer life; stainless steel to eliminate corrosion
- **Raised seat** reduces possibility of foreign matter accumulating on valve seat
- **Stainless steel spring**, corrosion resistant for long life
- **Heat stabilized nylon seat disc** for easy positive shut-off
- **Positive backseating** with valve in wide open position
- **Recommended** for vacuum applications and service pressures up to 500 PSI (35 Kg/cm²)
- **Temperature rating:** -20°F (-29°C) to +275°F (+135°C)
- **Suitable for refrigerants** and other hazardous or expensive industrial fluids non-corrosive to brass, copper and stainless steel

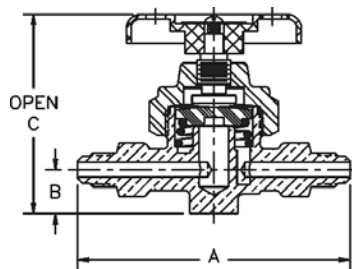

Type 515

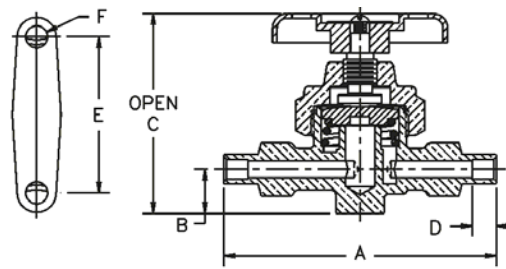

Type 516



Type	Catalog Number	Size Connection	Dimensions in Inches						Weight lbs
			A	B	C	D	E	F	
515	5151	1/4" FL	2.63	.56	2.56	—	2.00	.28	.62
515	5153	3/8" FL	2.88	.56	2.56	—	2.00	.28	.74
516	5161	1/4" ODS	3.25	.56	2.56	.31	2.00	.28	.77
516	5163	3/8" ODS	3.50	.56	2.56	.38	2.00	.28	.78
516	5164	1/2" ODS	3.88	.63	2.94	.38	2.00	.28	1.12
516	5165	5/8" ODS	4.13	.75	3.00	.56	2.00	.28	1.29

PACKLESS VALVES

Standard Type

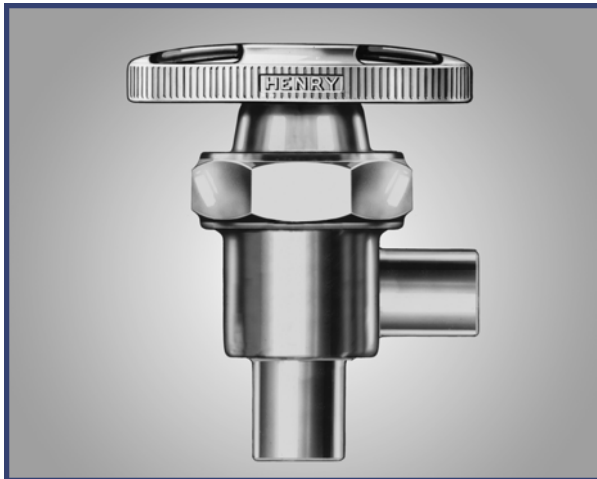
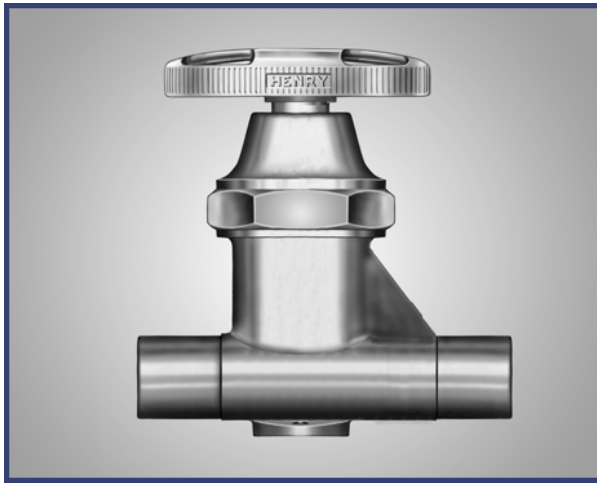

Features:

- **Forged brass cored body** provides durability, maximum rigidity, strength. Integral mounting bracket on valves simplifies installation
- **Forged brass bonnet** machined to provide support for diaphragms when valve is wide open
- **Hermetic seal** between bonnet, diaphragms and body
- **Large diameter diaphragms** of dissimilar metals permit greater lift, aids flow and longer life. Phosphor bronze for longer life; stainless steel to eliminate corrosion
- **Raised seat** reduces possibility of foreign matter accumulating on valve seat
- **Stainless steel spring**, corrosion resistant for long life
- **Heat stabilized nylon seat disc** for easy positive shut-off
- **Positive backseating** with valve in wide open position
- **Recommended** for vacuum applications and service pressures up to 500 PSI (35 Kg/cm²)
- Temperature rating: -20°F (-29°C) to +275°F (+135°C)
- Suitable for refrigerants and other hazardous or expensive industrial fluids non-corrosive to brass, copper and stainless steel
- **Balanced action**
- **Non-directional flow**
- **Backseating lower stem**
- **Diaphragms are changeable under line pressure**
- **Standard globe and angle valves** are designed in conformance with MIL-V-20064E and Military Standards MS-35880, MS-35881, and MS-35883

PACKLESS VALVES

Standard Type

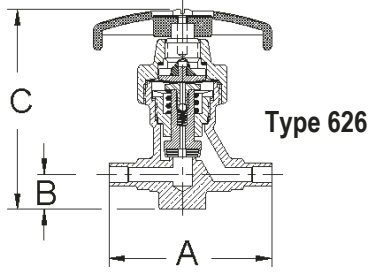

Type 626

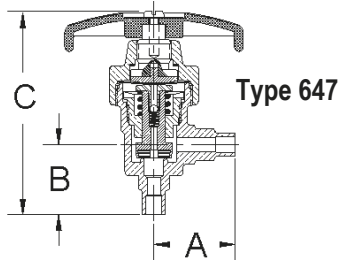

Type 647

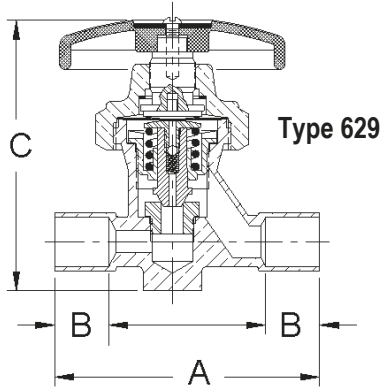

Type 629

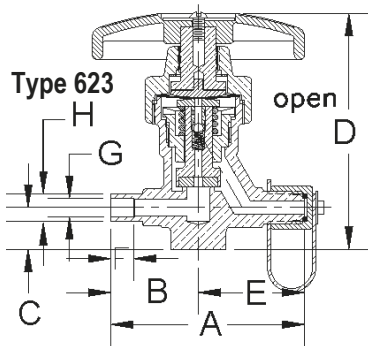

Type 623

open

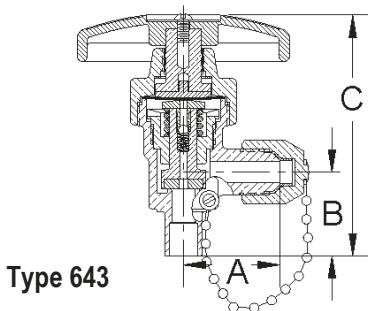

Type 643

Standard Globe Valves O.D. Solder	Catalog No.	Size Connection	Dimensions in Inches				Weight lbs.
			A	B	C	Mtg. Hole Ctr.	
	6261N	1/4" O.D.S.	2.63	.63	3.38	1.63	1.00
	6263N	3/8" O.D.S.	2.63	.63	3.38	1.63	1.00
	6264N	1/2" O.D.S.	3.13	.63	3.63	1.75	1.25
	6265N	5/8" O.D.S.	3.50	.75	3.75	2.00	1.13
	6266N	3/4" O.D.S.	4.38	.75	5.00	2.25	2.75
	6267N	7/8" O.D.S.	4.88	.75	5.38	2.5	3.25
	6268N	1-1/8" O.D.S.	6.00	1.00	6.50	3.25	5.50

Standard Angle Valves O.D. Solder	Catalog No.	Size Connection	Dimensions in Inches			Weight lbs.
			A	B	C	
	6471N	1/4" O.D.S.	1.38	1.13	3.50	.75
	6473N	3/8" O.D.S.	1.38	1.13	3.50	.75
	6474N	1/2" O.D.S.	1.50	1.25	3.50	1.00
	6475N	5/8" O.D.S.	1.50	1.38	3.88	1.25
	6476N	3/4" O.D.S.	1.88	1.50	4.88	2.25
	6477N	7/8" O.D.S.	2.13	1.88	5.38	3.75
	6478N	1-1/8" O.D.S.	2.50	2.25	6.50	4.25

Hand Standard Type Hand Expansion Valves	Catalog No.	Size Connection	Ori. Dia	Dimensions in Inches			Mtg. Hole Dia.	Weight lbs.
				A	B	C		
	6291N	1/4" O.D.S.	.22	2.63	.63	3.38	1.63	1.00
	6293N	3/8" O.D.S.	.22	2.63	.63	3.38	1.63	1.00
	6294N	1/2" O.D.S.	.22	2.63	.63	3.38	1.63	1.00
	6295N	5/8" O.D.S.	.28	3.38	.63	3.50	1.75	1.25
	6296N	3/4" O.D.S.	.34	3.88	.75	3.75	2.00	1.38
	6297N	7/8" O.D.S.	.38	4.38	.75	5.00	2.25	2.75
	6298N	1-1/8" O.D.S.	.44	4.88	.75	5.38	2.50	3.25

Standard Globe Valves O.D. Solder	Catalog No.	Size Connection	Dimensions in Inches				Weight lbs.
			A	B	C	Mtg. Hole Ctr.	
	6231N	1/4" O.D.S. x 1/4" FL.	2.63	.63	3.38	1.63	1.00
	6232N	3/8" O.D.S. x 3/8" FL.	2.63	.63	3.38	1.63	1.00
	6233N	1/2" O.D.S. x 1/2" FL.	3.25	.63	3.63	1.75	1.25
	6234N	5/8" O.D.S. x 5/8" FL.	3.75	.75	3.75	2.00	1.38

Standard Angle Valves O.D. Solder	Catalog No.	Size Connection		Dimensions in Inches			Weight lbs.
		Bottom	Side	A	B	C	
	6432N	3/8 O.D.S.	3/8 FL.	1.31	1.13	3.25	.78
	6433N	1/2 O.D.S.	1/2 FL.	1.63	1.19	3.33	1.15
	6434N	5/8 O.D.S.	5/8 FL.	1.75	1.38	3.82	1.35