

# CHILLERS

## Flooded Shell and Tube

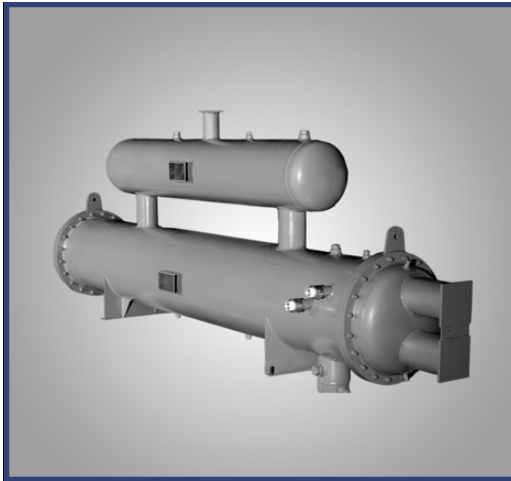

Suitable for Ammonia



Dimensions in Inches	
"A" Nominal Dia.	"B"
8	2 3/4
10	3 1/2
12	3 3/4
14	4 3/4
16	6 1/2
18	7 3/8
20	7 1/2
24	8 1/2
30	10
36	10 1/2
42	13
48	14 1/2

### Specifications:

- **Straight-through tube construction** with removable heads at both ends; head passes with integral baffles to provide proper fluid velocity with minimum pressure drop
- **Codes:** Construction to Section VIII of the ASME Code and CSA B-51, B-52 and C-22.2 Codes; available with U symbol stamp (i.e. National Board approval) when required
- **Working Pressures:** Shell side: 250 PSI  
Tube side: 150 PSI
- **Heads:** Fabricated carbon steel with integrally welded pass divisions
- **Tubes:** 3/4" O.D. 16 gauge SA-179 seamless carbon steel
- **Tube Sheets:** Carbon steel SA 516-70 plate; tube holes are reamed and double grooved
- **Connections:** Water-3" and smaller, MPT steel pipe; connections 4" and larger, pipe stubs;  
Ammonia-2" and smaller, MPT; 3 and larger, pipe stubs;  
Freon-ODF as standard unless otherwise specified
- **Surge Drum:** Minimum 250 PSI working pressure, attached to liquid chiller by suction risers welded to both shells; two risers are standard; third riser supplied on larger units where required
- **Available Nominal Tube Lengths (N.T.L.):** 6'6", 8', 10', 12', 14', 16', 18', 20', 22', 24', 26', 28', 30'
- **Available Surge Drum Nominal Diameters (S.D.):** 6", 8", 10", 12", 14", 16", 20", 24", 30", 36", 42", 48"
- **All units are custom designed** according to the thermal duty and your requirements

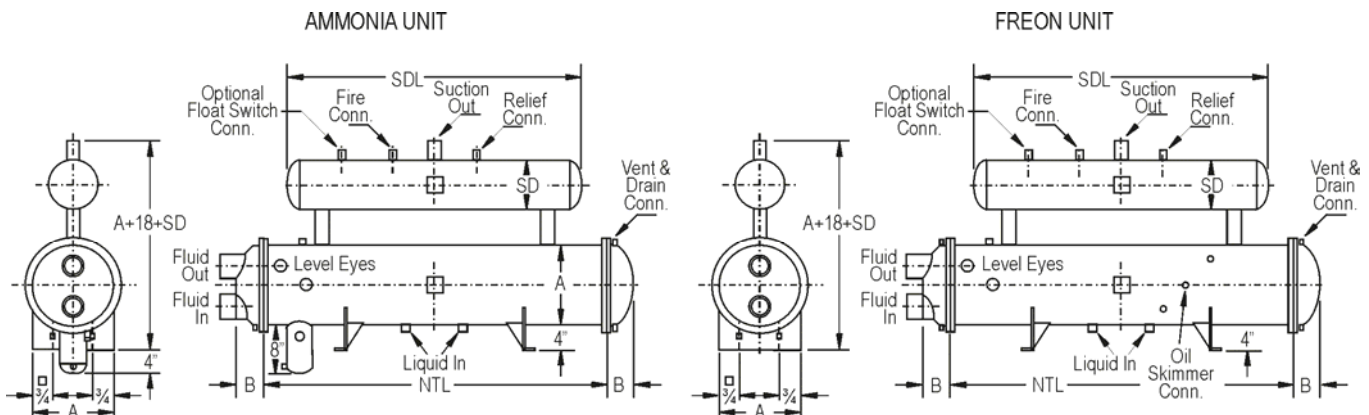

Code: SD - Surge Drum; SDL - Surge Drum Length; NTL - Nominal Tube Length



Industrial & Commercial Refrigeration Products 800.96.HENRY